

### OVERVIEW

This application note discusses how to connect the DS31256 Envoy to the DS2155, DS21Q55, and DS21Q50 in T1/E1, 2MHz, 4MHz, 8MHz clock mode. The hardware connection and software configuration details are given.

Dallas Semiconductor offers a complete line of communications products. The devices provide highly integrated solutions for applications including T-carrier and E-carrier, broadband, and so on.

The DS31256 Envoy has 256 independent directional HDLC channels and supports up to 64 T1 or E1 data streams simultaneously. It supports 16 channelized or unchannelized ports and each channelized port can handle one, two or four T1 or E1 lines. There are also three fast ports on the Envoy that can each handle up to 52Mbps in both transmit and receive directions, suitable for VDSL, HSSI, or clear-channel T3 applications. All 16 ports can operate from 0 to 10Mbps when configured in unchannelized mode, and gapped clocking is supported on all ports.

The DS2155 and DS21Q55 enable the user to select—under software control—T1, E1, or J1 protocol. This simplifies the design of low-cost multiprotocol interfaces. A high-performance LIU, flexible architecture, and rich feature set make the DS2155 an excellent solution to all standard T1, E1, and J1 applications including routers, switches, muxes, ADMs, and CSU/DSUs.

The DS21Q50 contains all functions necessary for connecting to four E1 lines. It is ideally suited for E1 data pipe applications where high performance must be achieved at a low price. In addition to the four transceivers, an extra jitter attenuator resource is available to clean up transmit or backplane clocks. A clock synthesizer is available for generating backplane clocks from 2.048MHz to 16.384MHz and a single clock synthesizer can be shared between multiple DS21Q50s to facilitate smooth clock-source switching.

## 1. CONNECTION WITH DS2155

### 1.1 Connection in T1 Mode

#### Hardware Configuration

Figure 1 shows the connection between DS2155 and DS31256 in T1 mode. The receive elastic store is bypassed in the framer because the transmit clock is sourced from the RCLK pin. The transmit synchronization signal is sourced from the RSYNC pin.

**Figure 1. DS2155 Connected to DS31256 in T1 and E1 Mode**

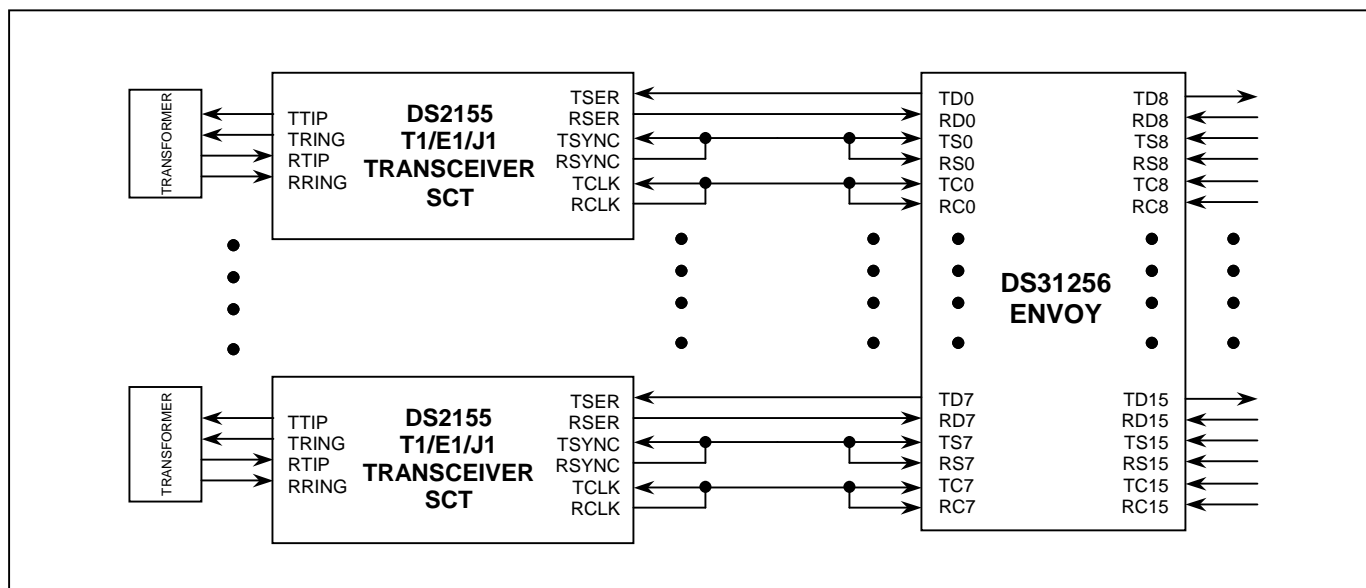

#### Software Configuration

Tables 1 and 2 show some of the critical register settings necessary to initialize the DS31256 and DS2155 for the operation described above. Note that they might not represent the complete register listing required for a customer application. The reader is encouraged to refer to device data sheets for further information regarding the flexibility of the DS31256 and DS2155.

**Table 1. Register Settings for DS31256 in T1 Mode**

SETTING	LOCATION	FUNCTION
RSS0 = 0 RSS1 = 0 RUEN = 0	RP[n]CR	Set Rx port T1 mode; Set Rx port channelized mode enable
TSS0 = 0 TSS1 = 0 TUEN = 0	TP[n]CR	Set Tx port T1 mode; Set Tx port channelized mode enable

**Table 2. Register Settings for DS2155 in T1 Mode**

SETTING	LOCATION	FUNCTION
T1/E1 = 0	MSTRREG.1	Select the T1 operating mode
TSIO = 0 RSIO = 0	IOCR1.1 IOCR1.4	TSYNC is an input RSYNC is an output
TCLKINV = 0 RCLKINV = 0	IOCR2.6 IOCR2.7	TCLK no inversion RCLK no inversion
RB8ZS = 1 RFM = 1	T1RCR2.5 T1RCR2.6	Receive B8ZS enabled Receive ESF framing mode
TB8ZS = 1	T1TCR2.7	Transmit B8ZS enabled
TFM = 1	T1CCR1.2	Transmit ESF framing mode
RESE = 0	ESCR.0	Receive elastic store is bypassed
TPD = 1	LIC1.0	Normal transmitter operation
TUA1 = 1 ETS = 0	LIC2.4 LIC2.7	Transmit data normally T1 mode selected

## 1.2 Connection in E1 Mode

### Hardware Configuration

The connection between DS2155 and DS31256 in E1 mode is similar to T1 mode. The PCM31 framing mode is selected. The Receive elastic store is bypassed. The Transmit Clock is sourced from the RCLK pin. The Transmit Synchronization signal is sourced from the RSYNC pin.

### Software Configuration

Tables 3 and 4 show some of the critical register settings necessary to initialize the DS31256 and DS2155 for operation as described above. Note that they might not represent the complete register listing required for a customer application. The reader is encouraged to refer to the device data sheet for further information regarding the flexibility of the DS31256 and DS2155.

**Table 3. Register Settings for DS31256 in E1 Mode**

SETTING	LOCATION	FUNCTION
RSS0 = 0 RSS1 = 1 RUEN = 0	RP[n]CR	Set Rx port E1 mode; Set Rx port channelized mode enable
TSS0 = 0 TSS1 = 1 TUEN = 0	TP[n]CR	Set Tx port E1 mode; Set Tx port channelized mode enable

**Table 4. Register Settings for DS2155 in E1 Mode**

SETTING	LOCATION	FUNCTION
T1/E1 = 1	MSTRREG.1	Select the E1 operating mode
TSIO = 0	IOCR1.1	TSYNC is an input
RSIO = 0	IOCR1.4	RSYNC is an output
TCLKINV = 0	IOCR2.6	TCLK no inversion
RCLKINV = 0	IOCR2.7	RCLK no inversion
SYNCE = 0	E1RCR1.1	Receive auto resync enabled
RHDB3 = 1	E1RCR1.5	Receive HDB3 enabled
RSIGM = 1	E1RCR1.6	Receive CCS signaling mode
RCRC4 = 1	E1RCR1.3	Receive CRC4 enabled
TCRC4 = 1	E1TCR1.0	Transmit CRC4 enabled
THDB3 = 1	E1TCR1.2	Transmit HDB3 enabled
RESE = 0	ESCR.0	Receive elastic store is bypassed
TPD = 1	LIC1.0	Normal transmitter operation
TUA1 = 1	LIC2.4	Transmit data normally
ETS = 1	LIC2.7	E1 Mode Selected

## 2. CONNECTION WITH DS21Q55

### 2.1 Connection in T1 Mode

#### Hardware Configuration

Figure 2 shows the connection between DS21Q55 and DS31256 in T1 mode. The receive elastic store is bypassed. The transmit clock is sourced from RCLK pins. The transmit synchronization signal is source from RSYNC pins.

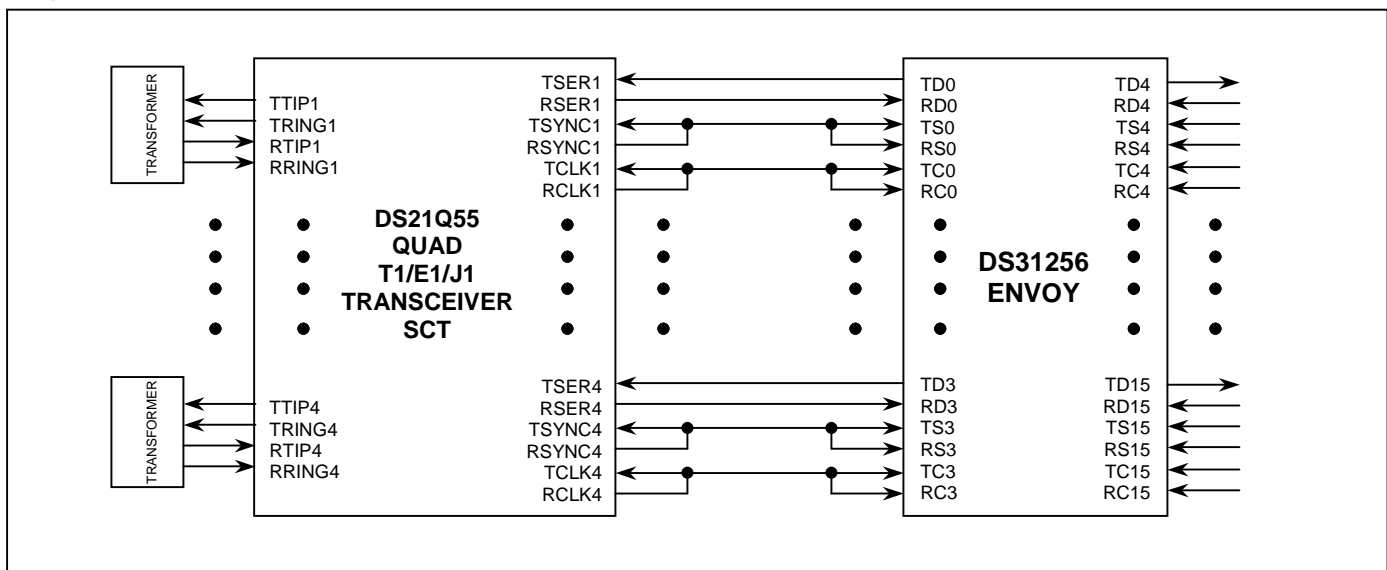
**Figure 2. DS21Q55 Connected to DS31256 in T1 Mode**

## Software Configuration

Tables 5 and 6 show some of the critical register settings necessary to initialize the DS31256 and DS21Q55 for operation as described above. Note that they might not represent the complete register listing required for a customer application. The reader is encouraged to refer to the device data sheet for further information regarding the flexibility of the DS31256 and DS21Q55.

**Table 5. Register Settings for DS31256 in T1 Mode**

SETTING	LOCATION	FUNCTION
RSS0 = 0 RSS1 = 0 RUEN = 0	RP[n]CR	Set Rx port T1 mode;  Set Rx port channelized mode enable
TSS0 = 0 TSS1 = 0 TUEN = 0	TP[n]CR	Set Tx port T1 mode;  Set Tx port channelized mode enable

**Table 6. Register Settings for DS2155 in T1 Mode**

The following settings apply to all four ports (transceivers):

SETTING	LOCATION	FUNCTION
T1/E1 = 0	MSTRREG_S1.1	Select the T1 operating mode
TSIO = 0 RSIO = 0	IOCR1.1 IOCR.4	TSYNC is an input RSYNC is an output
TCLKINV = 0 RCLKINV = 0	IOCR2.6 IOCR2.7	TCLK no inversion RCLK no inversion
RB8ZS = 1 RFM = 1	T1RCR2.5 T1RCR2.6	Receive B8ZS enabled Receive ESF framing mode
TB8ZS = 1	T1TCR2.7	Transmit B8ZS enabled
TFM = 1	T1CCR1.2	Transmit ESF framing mode
RESE = 0	ESCR.0	Receive elastic store is bypassed
TPD = 1	LIC1.0	Normal transmitter operation
TUA1 = 1 ETS = 0	LIC2.4 LIC2.7	Transmit data normally T1 Mode Selected

## 2.2 Connection in 8M Mode

### Hardware Configuration

Figure 3 shows the connection between DS21Q55 and DS31256 in 8M mode. The four E1 data bus on the backplane bus is in frame interleave mode. The receive elastic store is enabled. The transmit clock is source from RCLK pin. The 8kHz transmit synchronization signal is generated from the RSYNC pin of the first device on the bus. All other devices on the bus have their frame syncs configured as inputs.

**Figure 3. DS21Q55 Connected to DS31256 in 8M Mode**

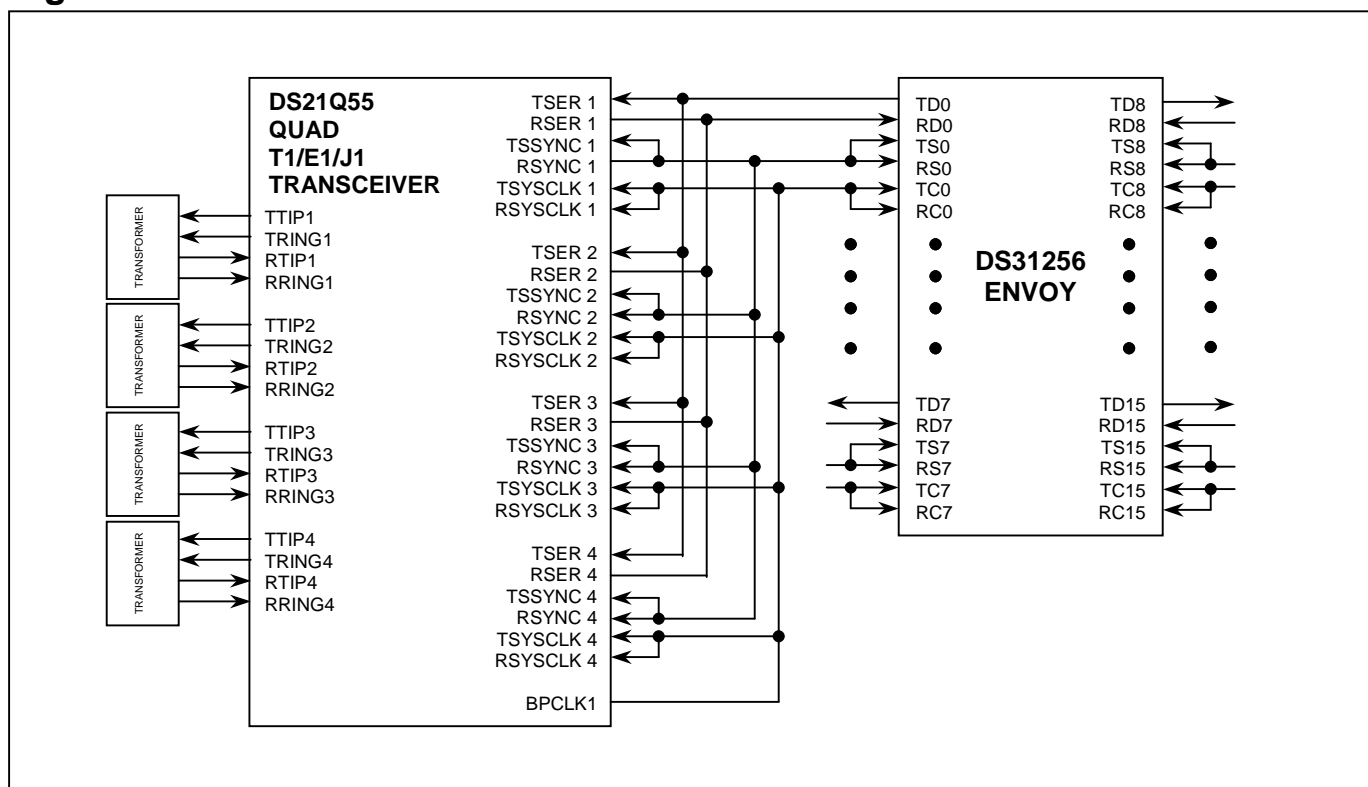

### Software Configuration

Tables 7 and 8 show some of the critical register settings necessary to initialize the DS31256 and DS2155 for operation as described above. Note that they might not represent the complete register listing required for a customer application. The reader is encouraged to refer to the device data sheet for further information regarding the flexibility of the DS31256 and DS2155.

**Table 7. Register Settings for DS31256 in 8M Mode**

SETTING	LOCATION	FUNCTION
RSS0 = 1 RSS1 = 1 RUEN = 0	RP[n]CR	Set Rx port 8.192MHz mode; Set Rx port channelized mode enable
TSS0 = 1 TSS1 = 1 TUEN = 0	TP[n]CR	Set Tx port 8.192MHz mode; Set Tx port channelized mode enable

## Table 8. Register Settings for DS21Q55 in 8M Mode

The following settings apply to all 4 ports (transceivers):

SETTING	LOCATION	FUNCTION
T1/E1 = 1	MSTRREG.1	Select the E1 operating mode
TCLKINV = 0	IOCR2.6	TCLK no inversion
RCLKINV = 0	IOCR2.7	RCLK no inversion
SYNCE = 0	E1RCR1.1	Receive auto resync enabled
RHDB3 = 1	E1RCR1.5	Receive HDB3 enabled
RSIGM = 1	E1RCR1.6	Receive CCS signaling mode
RCRC4 = 1	E1RCR1.3	Receive CRC4 enabled
TCRC4 = 1	E1TCR1.0	Transmit CRC4 enabled
THDB3 = 1	E1TCR1.2	Transmit HDB3 enabled
RESE = 0	ESCR.0	Receive elastic store is bypassed
TPD = 1	LIC1.0	Normal transmitter operation
TUA1 = 1	LIC2.4	Transmit data normally
ETS = 1	LIC2.7	E1 Mode Selected
RSCLKM = 1	IOCR2_S1.0	IBO enabled
TSCLKM = 1	IOCR2_S1.1	IBO enabled

The following settings apply to the specified port (transceiver):

SETTING	LOCATION	FUNCTION
BPEN = 1 BPCS0 = 1 BPCS1 = 0	TC#1, CCR2.0 TC#1, CCR2.1 TC#1, CCR2.2	Enable BPCLK1 pin Backplane clock select 8.192MHz
TSIO = 0 RSIO = 0	TC#1, IOCR1.1 TC#1, IOCR1.4	TSYNC1 is an input RSYNC1 is an output
TSIO = 0 RSIO = 1	TC#2, IOCR1.1 TC#2, IOCR1.4	TSYNC2 is an input RSYNC2 is an input
TSIO = 0 RSIO = 1	TC#3, IOCR1.1 TC#3, IOCR1.4	TSYNC3 is an input RSYNC3 is an input
TSIO = 0 RSIO = 1	TC#4, IOCR1.1 TC#4, IOCR1.4	TSYNC4 is an input RSYNC4 is an input
DA0= 0 DA1= 0 DA2= 0 IBOEN = 1 IBOSEL = 1 IBS0 = 1 IBS1 = 0	TC#1, IBOC .0 TC#1, IBOC .1 TC#1, IBOC .2 TC#1, IBOC .3 TC#1, IBOC .4 TC#1, IBOC .5 TC#1, IBOC .6	This is the Transceiver #1 on the bus.  Interleave Bus Operation enabled Frame Interleave Operation Four transceivers on the bus
DA0= 1 DA1= 0 DA2= 0 IBOEN = 1 IBOSEL = 1 IBS0 = 1 IBS1 = 0	TC#2, IBOC .0 TC#2, IBOC .1 TC#2, IBOC .2 TC#2, IBOC .3 TC#2, IBOC .4 TC#2, IBOC .5 TC#2, IBOC .6	This is the Transceiver #2 on the bus.  Interleave Bus Operation enabled Frame Interleave Operation Four transceivers on the bus
DA0= 0 DA1= 1 DA2= 0 IBOEN = 1 IBOSEL = 1 IBS0 = 1 IBS1 = 0	TC#3, IBOC .0 TC#3, IBOC .1 TC#3, IBOC .2 TC#3, IBOC .3 TC#3, IBOC .4 TC#3, IBOC .5 TC#3, IBOC .6	This is the Transceiver #3 on the bus.  Interleave Bus Operation enabled Frame Interleave Operation Four transceivers on the bus
DA0= 1 DA1= 1 DA2= 0 IBOEN = 1 IBOSEL = 1 IBS0 = 1 IBS1 = 0	TC#4, IBOC .0 TC#4, IBOC .1 TC#4, IBOC .2 TC#4, IBOC .3 TC#4, IBOC .4 TC#4, IBOC .5 TC#4, IBOC .6	This is the Transceiver #4 on the bus.  Interleave Bus Operation enabled Frame Interleave Operation Four transceivers on the bus

Where:

- TC#1 = Transceiver #1 (TS1, TS0 = 00)
- TC#2 = Transceiver #2 (TS1, TS0 = 01)
- TC#3 = Transceiver #3 (TS1, TS0 = 10)
- TC#4 = Transceiver #4 (TS1, TS0 = 11)



### 3. CONNECTION WITH DS21Q50

#### 3.1 Connection in 2M Mode

##### Hardware Configuration

Figure 4 shows the connection between the DS21Q50 and DS31256 in 2M mode. As the IBO function is disabled, the transmit clock of each port is source from TCLK pin, which is connected to SYSTLK1. The Layer 1 of DS31256 is configured as E1 port.

**Figure 4. DS21Q50 Connected to DS31256 in 2M Mode**

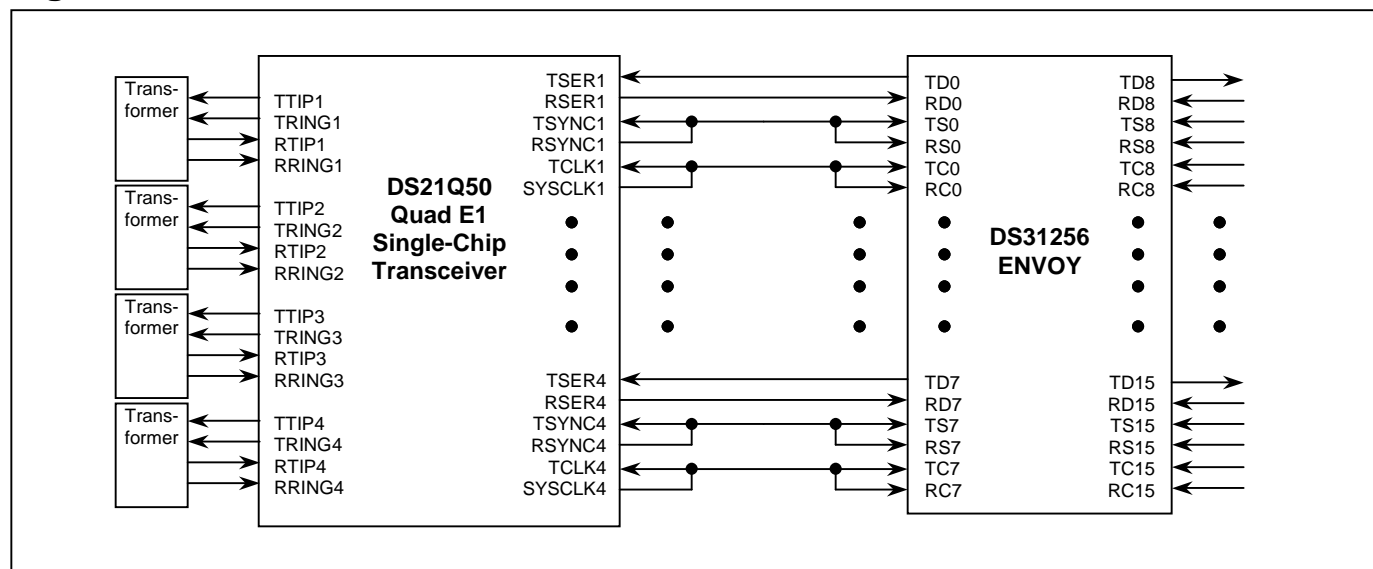

##### Software Configuration

Tables 9 and 10 show some of the critical register settings necessary to initialize the DS31256 and DS21Q50 for operation as described above. Note that they might not represent the complete register listing required for a customer application. The reader is encouraged to refer to the device data sheet for further information regarding the flexibility of the DS31256 and DS21Q50.

**Table 9. Register Settings for DS31256**

SETTING	LOCATION	FUNCTION
RSS0 = 0 RSS1 = 1 RUEN = 0	RP[n]CR	Set RX Port E1 mode; Set RX Port Channelized mode enable
TSS0 = 0 TSS1 = 1 TUEN = 0	TP[n]CR	Set TX Port E1 mode; Set TX Port Channelized mode enable

**Table 10. Register Settings for DS21Q50**

The following settings apply to all four ports (transceivers):

SETTING	LOCATION	FUNCTION
IBOEN = 0	IBO.3	Disable IBO operation
RSIO = 0	RCR.5	RSYNC pin is an output
RSM = 0	RCR.6	RSYNC is in frame mode
TSIO = 0	TCR.0	TSYNC is an input
TSM = 0	TCR.1	TSYNC is in frame mode

## 3.2 Connection in 8M mode

### Hardware Configuration

Figure 5 shows the connection between the DS21Q50 and DS31256 in 8M mode. In order to ensure data integrity in IBO mode, all clock and sync signals should be phase-aligned. The receive-elastic store for each of the four transceivers must be enabled. They should all receive the same frame-reference pulse (RSYNC) and 8.192MHz system clock (SYSCLK). In this case, the phase-locked frame pulse is provided by the system backplane; and the 21Q50's system-clock synthesizer provides the 8.192MHz clock. Note that the 8.192MHz clock can be created internally from any of the four E1 line recovered clocks. In IBO mode, the DS21Q50 can create transmit clock (TCLK) for each E1 formatter by dividing down the applied SYSCLK. The Layer 1 of DS31256 is configured as channelized 8MHz port.

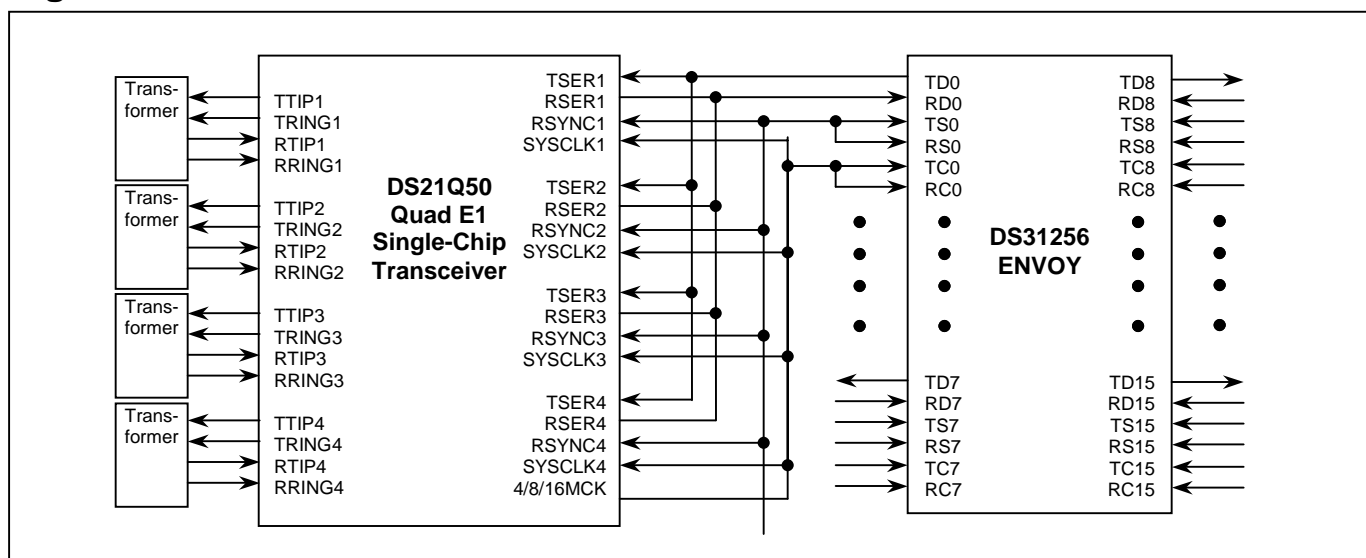
**Figure 5. DS21Q50 Connected to DS31256 in 8M Mode**

### Software Configuration

Tables 11 and 12 show some of the critical register settings necessary to initialize the DS31256 and DS21Q50 for operation as described above. Note that they might not represent the complete register listing required for a customer application. The reader is encouraged to refer to the device data sheet for further information regarding the flexibility of the DS31256 and DS21Q50.

**Table 11. Register Settings for DS31256**

The following settings apply to all four ports (transceivers):

SETTING	LOCATION	FUNCTION
RSS0 = 1 RSS1 = 1 RUEN = 0	RP[n]CR	Set RX Port 8.192MHz mode;  Set RX Port Channelized mode enable
TSS0 = 1 TSS1 = 1 TUEN = 0	TP[n]CR	Set TX Port 8.192MHz mode;  Set TX Port Channelized mode enable

**Table 12. Register Settings for DS21Q50**

The following settings apply to all four ports (transceivers):

SETTING	LOCATION	FUNCTION
IBOEN = 1	IBO.2	Enable IBO operation
IBOTCS = 1	IBO.6	Transmit clock derived from SYSCLK
SCS0 = 0 SCS1 = 1	IBO.4 IBO.5	8.192MHz operation (4 ports on the PCM bus)
RESE = 1	RCR.4	Enable receive elastic store
RSIO = 1	RCR.5	RSYNC pin is an input
RSM = 0	RCR.6	RSYNC is in frame mode
TSIO = 1	TCR.0	TSYNC is an output
TSM = 0	TCR.1	TSYNC is in frame mode

The following settings apply to the specified port (transceiver):

SETTING	LOCATION	FUNCTION
SCS0 = 1 SCS1 = 0 SCS2 = 0	TC#1, SCICR.0 TC#1, SCICR.1 TC#1, SCICR.2	Select the recovered clock from transceiver #1 as the source for the system clock synthesizer
CSS0 = 0 CSS1 = 1	TC#1, SCICR.3 TC#1, SCICR.4	8.192MHz operation (4 ports on the PCM bus)
SOE = 1	TC#1, SCICR.5	Enable synthesizer clock output
DA0 = 0 DA1 = 0 DA2 = 0	TC#1, IBO.0 TC#1, IBO.1 TC#1, IBO.2	Set transceiver #1 as first device on PCM bus
DA0 = 1 DA1 = 0 DA2 = 0	TC#2, IBO.0 TC#2, IBO.1 TC#2, IBO.2	Set transceiver #2 as second device on PCM bus
DA0 = 0 DA1 = 1 DA2 = 0	TC#3, IBO.0 TC#3, IBO.1 TC#3, IBO.2	Set transceiver #3 as third device on PCM bus
DA0 = 1 DA1 = 1 DA2 = 0	TC#4, IBO.0 TC#4, IBO.1 TC#4, IBO.2	Set transceiver #4 as fourth device on PCM bus
TSM = 0	TCR.1	TSYNC is in frame mode

Where:

- TC#1 = Transceiver #1 (TS1, TS0 = 00)
- TC#2 = Transceiver #2 (TS1, TS0 = 01)
- TC#3 = Transceiver #3 (TS1, TS0 = 10)
- TC#4 = Transceiver #4 (TS1, TS0 = 11)